





Versión corporativa (con FH sombra-degradada)



Versión simple, sin FH sombra-degradada

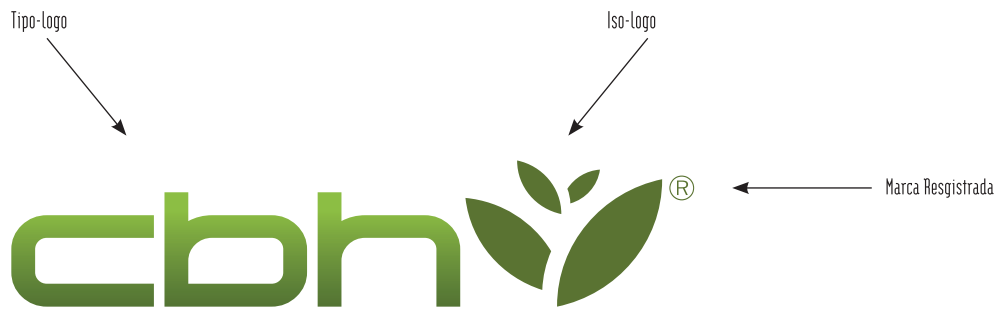

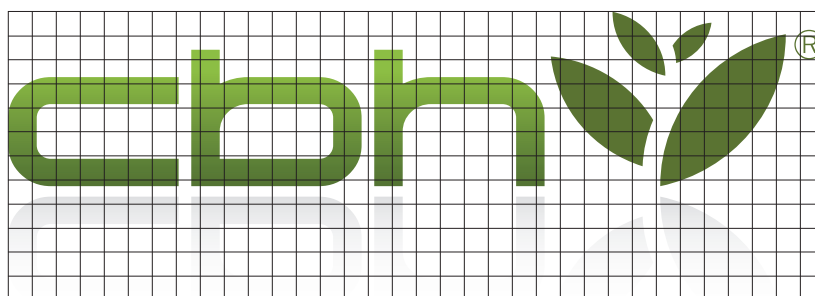

Construcción de la marca

Para un correcto escalado y unas proporciones óptimas hemos construido el logotipo sobre una estructura reticulada que facilita su construcción y mejora la simetría y proporciones de la logo-marca.

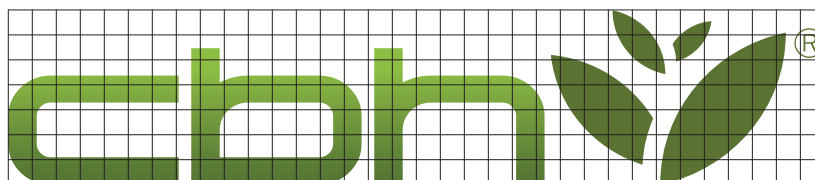

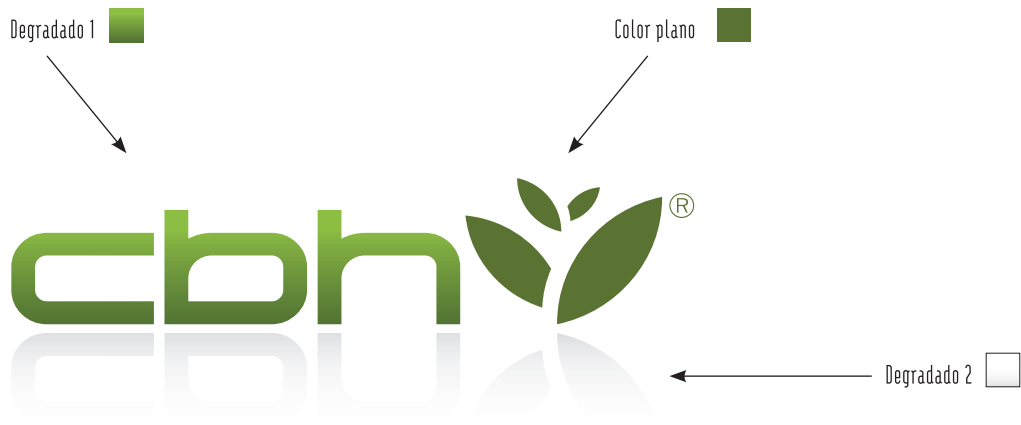

CBH Construcción de los degradados

Los degradados 1 y 2 tienen un punto de transición ubicado en el 15% y una inclinación de -90 grados.

.....

 **Degradado 1:**  C65, M35, Y100, K22  C50, M5, Y97, K0

.....

 **Color plano:** C65, M35, Y100, K22

.....

 **Degradado 2:**  15% black process  White

.....



Este logotipo ha sido construido e ideado en colores CMYK. Los pantones que mencionamos son equivalencias aproximadas a los valores en cuatricromía.



Color 1: C50, M5, Y97, K0 (pantone similar: 373U)



Color 2: C65, M35, Y100, K22 (pantone similar: 377U)



Degradado 2: 10% black process

Version corporativa con degradados



Version corporativa plana



Version 1 tinta plana, pantone 373



Version 1 tinta plana, pantone 377



Version 1 tinta plana, black process



Version 1 tinta plana, pantone 377



Version 1 tinta plana, pantone 373



Version sobre degradados



Version negro Black Process



La tipografía de la marca CBH está diseñada en exclusividad para el uso de la marca, por lo tanto no consta de alfabeto corporativo. Tan solo existen los caracteres C-B-H. Para las divisiones de marca si que hemos desarrollado un alfabeto externo de apoyo, con la tipografía "Wasava Romina Squared regular" en su versión minúscula, con la primera letra en mayúscula.

Para el diseño de material corporativo, así como la papelería de la marca, se recomienda el uso de la tipografía "Modula Regular" con un valor de (20) en el espaciado entre caracteres.

Wasava Romina Squared regular

a b c d e f g h i j k l m n ñ o p q r s t u v w x y z
A B C D E F G H I J K L M N Ñ O P Q R S T U V W X Y Z
1 2 3 4 5 6 7 8 9 0
! | ? ¿ () / & % \$. # " " , : ; : - _

Wasava Romina Squared regular

a b c d e f g h i j k l m n ñ o p q r s t u v w x y z
A B C D E F G H I J K L M N Ñ O P Q R S T U V W X Y Z
1 2 3 4 5 6 7 8 9 0
! | ? ¿ () / & % \$ 9 # " " , : ; : - _



Máximo Cañete Baquerizo presidente

Pol. Ind. Las Quemadas
c/ Imprenta de La Alborada, parc. 121 D. • 14014 Córdoba
Tlf.: +34 957 813 381 / Fax: +34 957 811 135 / Móv.: +34 670 811 030

maximo@cbh.es
www.cbh.es



Rafael Sánchez Gavilán director general

Pol. Ind. Las Quemadas
c/ Imprenta de La Alborada, parc. 121 D. • 14014 Córdoba
Tlf.: +34 957 813 381 / Fax: +34 957 811 135 / Móv.: +34 610 462 723

rafael@cbh.es
www.cbh.es





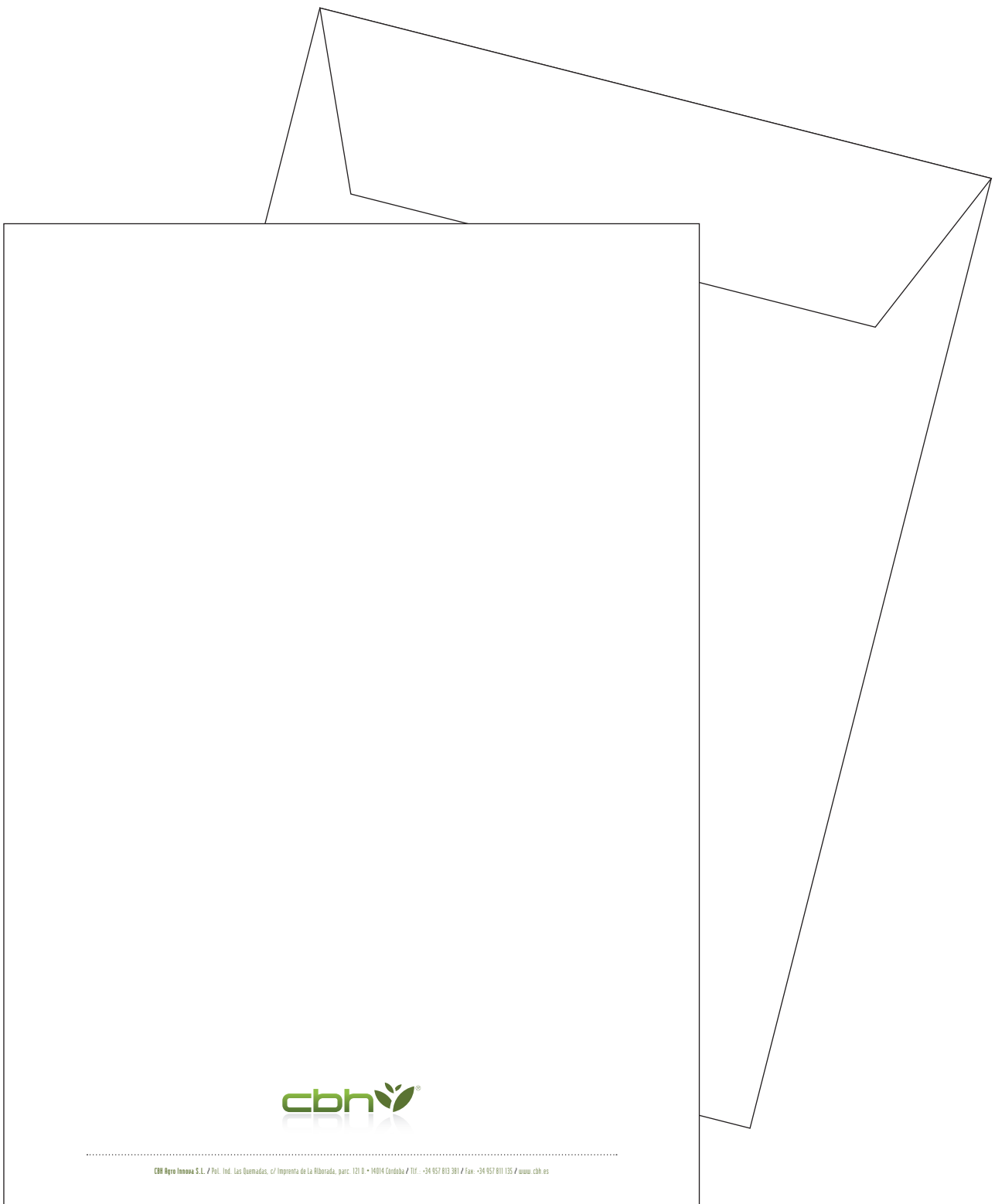





Agro / Fito / Aqua / Maq / World
http://www.cbh.com.ar

Agro / Fito / Aqua / Maq / World

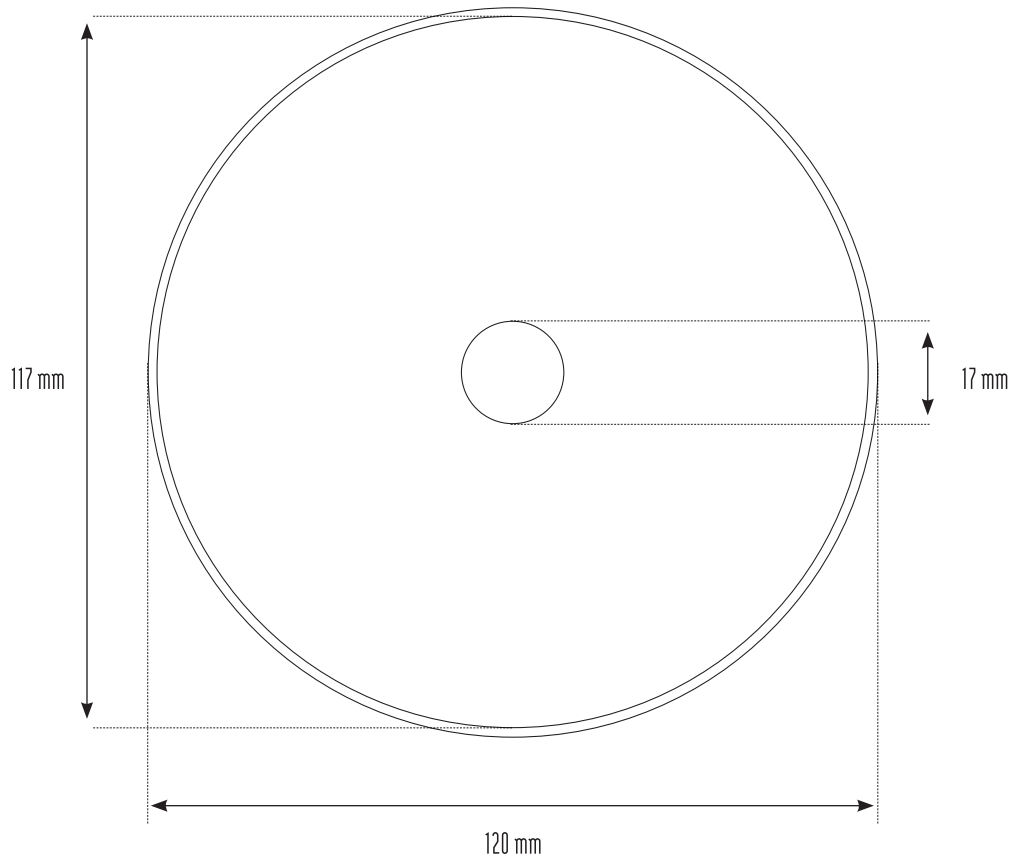



CBH Grupo Innova S.L. / C.I.F.: 823368848 / Pol. Ind. Las Quemadas, c/ Imprenta de La Alborada, parc. 121 D. • 14014 Córdoba / Tlf.: +34 957 813 381 / Fax: +34 957 811 135 / www.cbh.es

Urgente

Para revelar

Comentarios

Responder

Reciclar

Para

De

Fax

Fecha

Ref

Páginas

Asunto

Reciba un cordial saludo
Máximo Cañete
Presidente



No imprimas si no es necesario.
Si imprimas usa papel reciclado.

La información contenida en este mensaje de correo electrónico es confidencial. La misma es enviada con la intención de que únicamente sea leída por la persona(s) a la(s) que va dirigida. El acceso a este mensaje por otras personas no está autorizado. Si Vd. no es la persona a la que va dirigido, cualquier divulgación, copia, distribución de la información queda prohibida y puede ser ilegal. Asimismo, cualquier acción tomada o dejada de tomar basada en la información contenida en este mensaje queda prohibida y puede ser ilegal. Si el mensaje va dirigido a clientes, las opiniones o recomendaciones contenidas en el mensaje se entienden sujetas a los términos y condiciones pactadas con CBH.

The information in this email is confidential and may be legally privileged. It is intended solely for the addressee. Access to this email by anyone else is unauthorised. If you are not the intended recipient, any disclosure, copying, distribution or any action taken or omitted to be taken in reliance on it, is prohibited and may be unlawful. When addressed to our clients any opinions or advice contained in this email are subject to the terms and conditions dealt with CBH.

Inbox - 247 messages

←----- Ancho Max. 650 píxeles -----→





